

What are the details of our LED Light Bard.?

Die-cast aluminum housing, surface treatment for electrostaic coating

UV-Stop PC lamp cover

Sealed lamp housing

What are the specifications of ours [CARRIED Light Bard.?](#)

Insulation class	Power supply	LED Current	Power factor	Work environment	Duration	CRI.	CCT.
Class I.	120-277V. 50 / 60Hz.	700mA.	> 0.95.	-35. ° C to +45 ° C.	> 30,000 hours	RA> 75.	3000K-6500K.

Product code

Ymeled-6218.

Qty LED.

4 pcs.

Nominal power

8W.

Luminous flux

500-600lm.

G.W / N.W.

5 / 4.5kgs.

Packing size

250x250x830mm.

Product photo.



YM-6218

RAL 7015



RAL 9005



Die cast aluminum housing
CREE LED Chip / Meanwell driver
Height can be customized



CE IP65

Certificate

Certificate



Product Dimensions(mm)

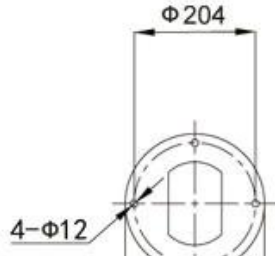
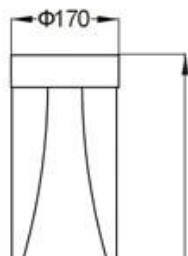

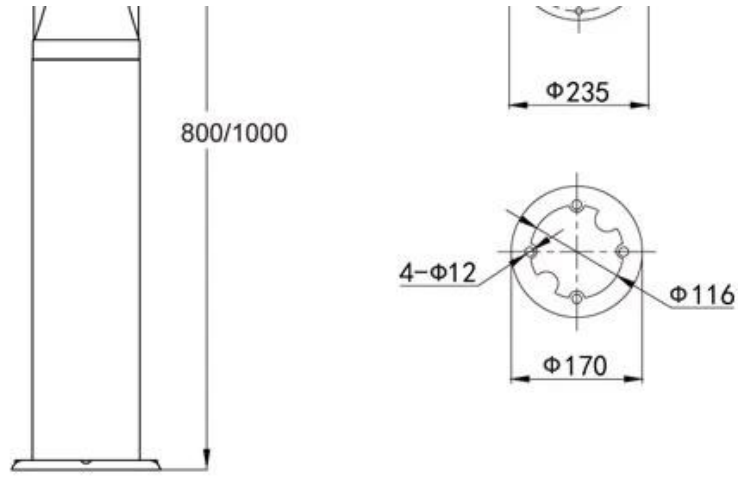

Configuration Data:

Protection grade	Corrosion-proof capability	Working condition	Isolation class	Power voltage	Max power
IP65	II 类	-35°C ~ +45°C	class I	120~277V 50/60Hz	8W(SMT)





Company Profile

Yuyao Yangming Lighting Co., Ltd. is mainly engaged in the development and production of garden lighting. Founded in 2001, it has developed more than 200 kinds of Garden lights, street lights, lawn lights, footpath lights, light poles, led lights and wall lights.

Now we are creating our own brands and developing products suitable for market. Welcome all friends to contact us. We will make contribution to lightening your home.





Testing and Design

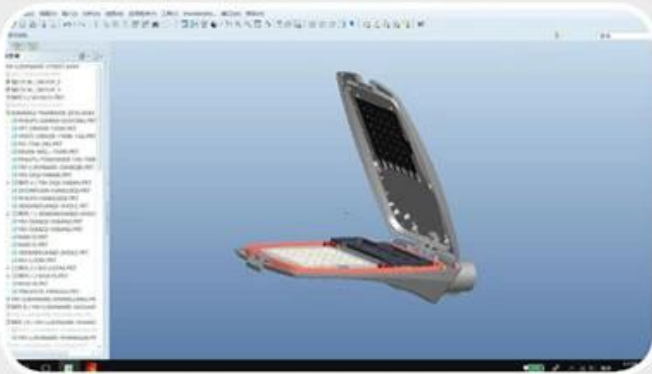

product design



ingress protection (Ip) testing equipment.



led street lighting aging testing line.

ingress protection (IP) testing equipment

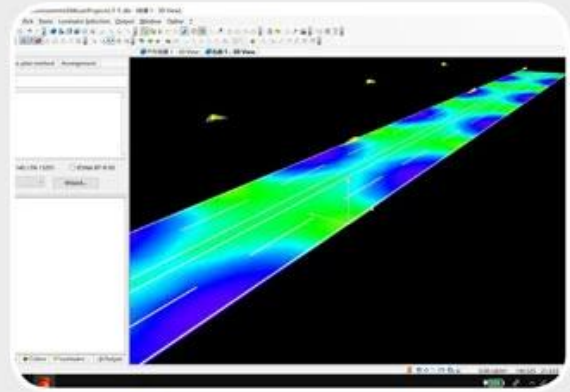

road lighting simulation

ullbrich sphere for testing luminous flux

Exhibittion

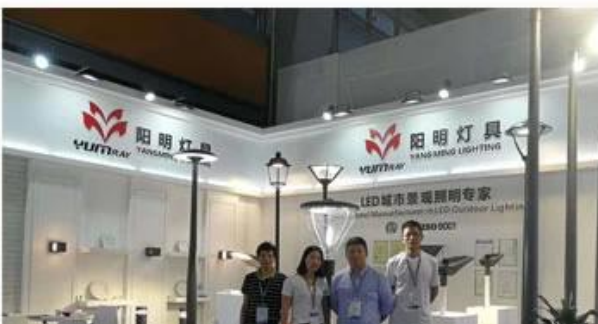
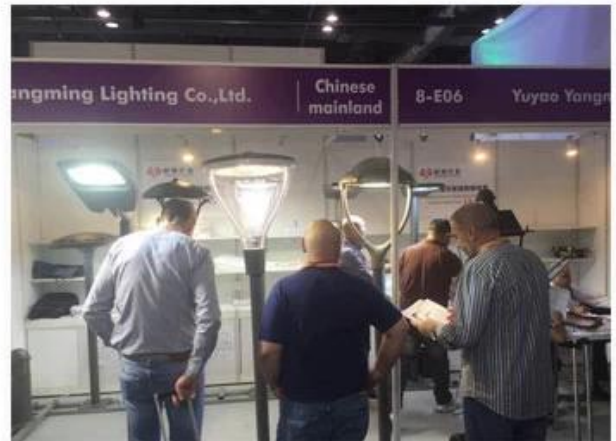



Add : Minyin industrial Zone, Liangnong Town,
Yuyao,Zhenjiang,China

Sale: 0574-22222345 / 22719888

0574-22672345(Fax)

Hotline: 0574-62359099

0574-62359077(Fax)

Http://www.ym-lighting.com

www.yyym2001.1688.com

www.yangminglamps.en.alibaba.com

Packaging and shipping, Business terms:

Shipment

1. **FedEx / DHL / UPS / TNT** for **samples**, Door to door,
2. **By air or by sea** for **Batches**, for FCL; Airport / port that receives,
3. Customers who specify trade shippers or shipping methods,
- 4 **Delivery time**: 5-7 days for samples; 15-30 Days for batch goods.

Payment terms

1. Payment: **T / T., Western Union, Moneygram., Paypal.;** **30% deposits; 70% balance** before the delivery,
2. MOQ: **1pcs,**
3. Warranty: 5 years