

□□□□□□□□□□□□□□□□? led □□□□~□□□□

□□ □□ □□□□ □□□□
□ □ □□ □□□ □□
□□□□ □□ □□ □□

LED □□□□□□□□□□□□□□□□? □□?

□□ □□	□□ □□ □□	LED □□	□□	□□□□□□ □□	□□	□□□□	CCT.
□□□□ I.	220-240V. 50 / 60hz.	700mA.	> 0.95.	- 40. °C ~ + 55 °C□□	> 50,000hrs.	ra> 70.	3000K-6500K.

□□□□□□



YMLED-6408L

RAL 7015



RAL 9005



Power range: 80W-180W

CREE XPG3 LED chip

Philips driver

>120LM/W

Quick and tool free open



IP66

IK08



Certificate



Product Dimensions(mm)

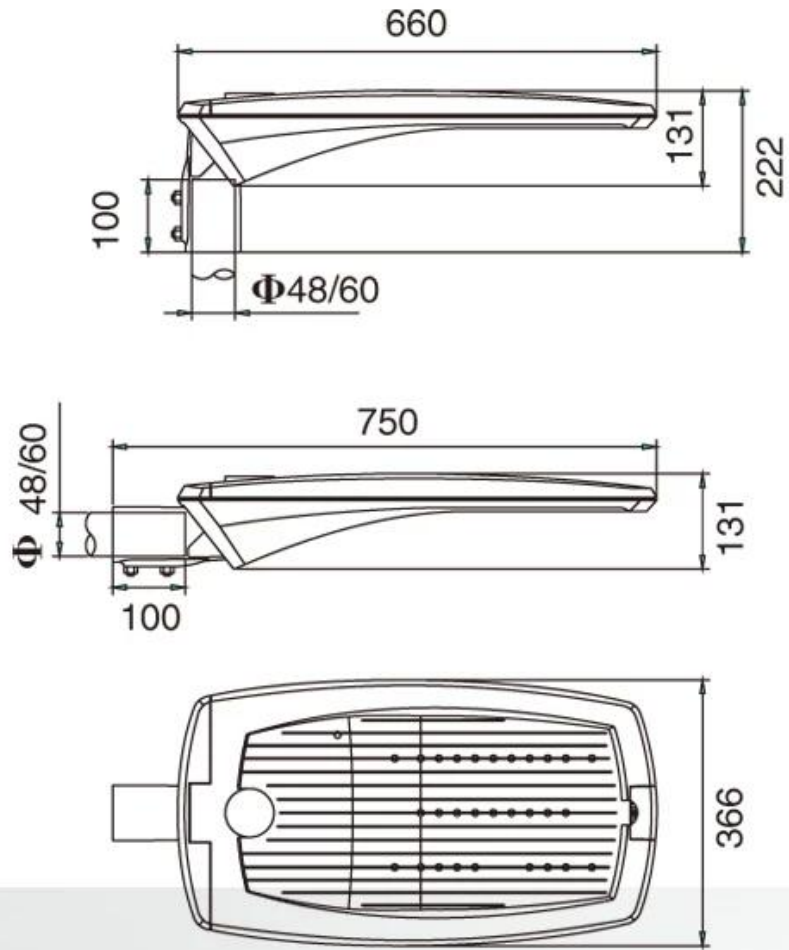

Internal Structure

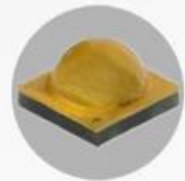

CREE XPG3 LED chip



Polar Diagram

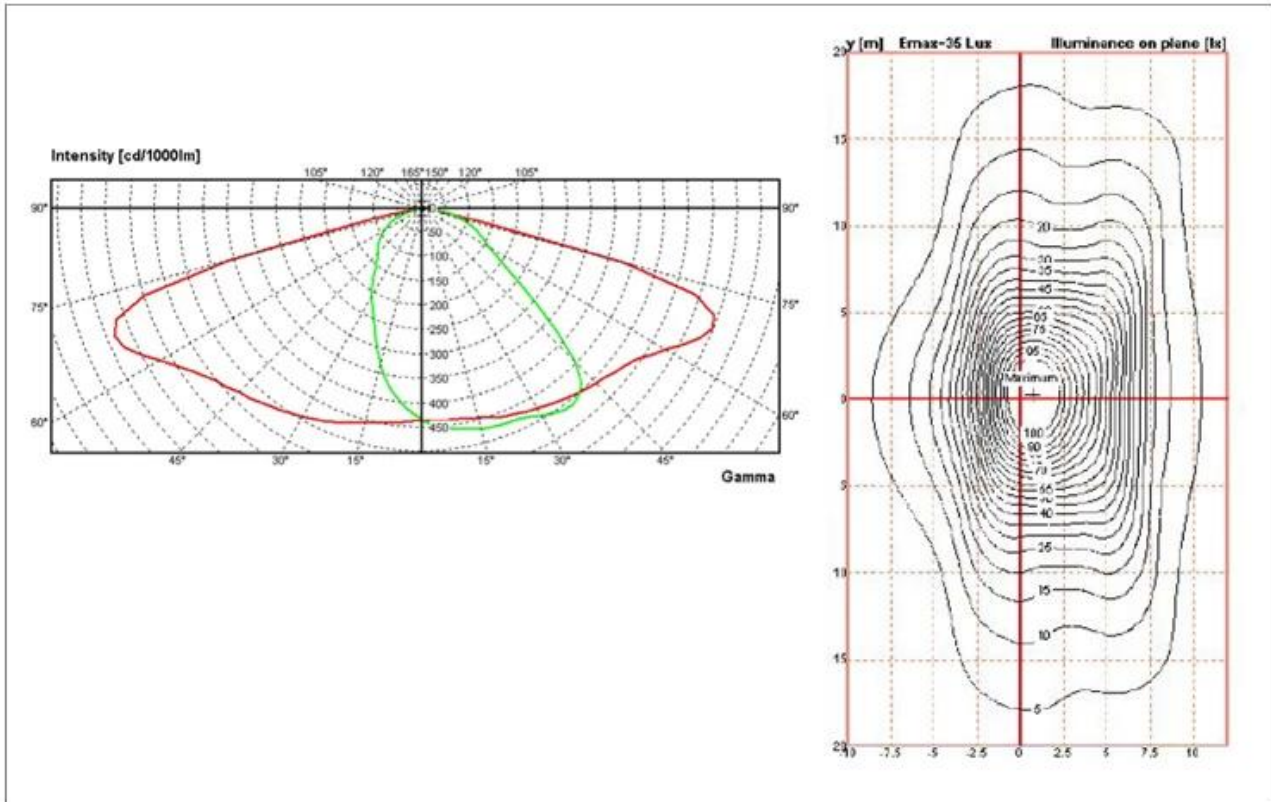

Configuration Data:

产品型号 Product Code	额定功率 Rated Power (led current 530mA)	初始光通量 Nominal initial FLUX	额定功率 Rated Power (led current 700mA)	初始光通量 Nominal initial FLUX	毛净重 G.W/N.W	包装尺寸 Packing Size
Galaxy max(48)	80W	10304lm	104W	12544lm	9/10(kgs)	770*400*160MM
Galaxy max(64)	105W	13440lm	140W	16800lm	9/10(kgs)	770*400*160MM
Galaxy max(80)	135W	17024lm	180W	21056lm	9/10(kgs)	770*400*160MM

□□□□□□, □□□□□□ :

-
1. FedEx / DHL / UPS / TNT. ~□□□□ □□, □□ - □,
 2. □□ □□ □□□ ~□□□□ □□ □□, fcl; □□ / □□ □□,
 3. □□ □□ □□ □□ □□ □□ □□□□ □□,
 4. □□ □□: 5.□□□□□□ -7 □; 15.-30. □□ □□ □.
- □□
1. □□ : T / T., □□□ □□□, □ □□,□□□...□ 30 % □□...□ 70 % □□ □□ □□,
 2. MOQ : 1pcs,
 3. □□ : 5years.